

SWL SERIES - **SWL1850**

SWL Valve Regulated Lead-Acid Batteries (VRLA)

The SWL range is an enhanced NPL design resulting in an improved energy to density ratio, giving up to 40% extra discharge capacity. All other attributes and operational characteristics are the same, thereby maintaining the benefit of a common mechanical and electrical design for users of both products.



FEATURES

- Yuasa VRLA batteries can be used in any orientation excluding continuous use inverted.
- Standard case material is flame retardant to (UL94) HBØ.
- FR option case material is flame retardant to UL94:VØ (oxygen index 30).
- SWL batteries are manufactured in factories that comply with ISO9001:2000.
- FR option SWL's comply with BS6290 Part 4 (1997).
- SWL batteries comply with IEC 60896-21+22.

Layout

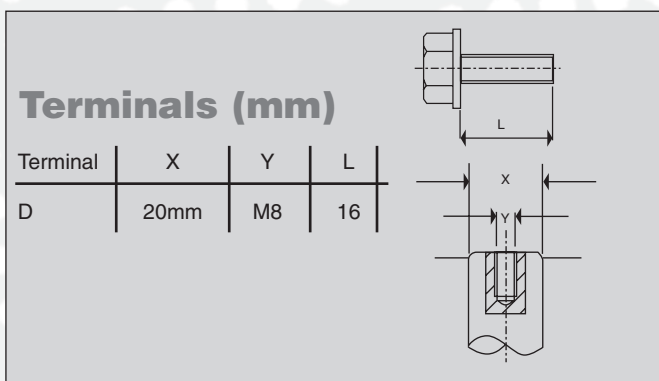
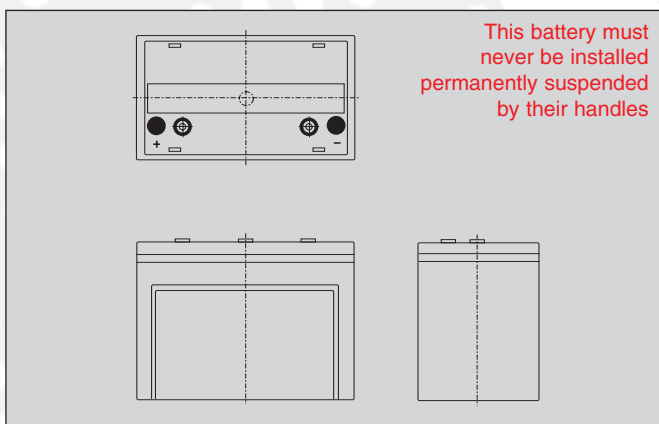

General Specifications

Specifications	SWL1850
1) Nominal Voltage	12
2) Nominal Wattage/Cell	
10 min to 1.6V/Cell	319
5 min to 1.6V/Cell	453
3 min to 1.6V/Cell	536
3) Weight (Approx)/Kg	23.8
4) Energy Density (Wh/L)	88
5) Specific Energy (Wh.kg) 10HR	39
6) Internal Resistance (Approx)/mohm	4.4
7) Maximum (1 min) discharge Current/A	500
8) Maximum Short Duration (1 sec) Discharge Current in Amperes	800
9) Operating Temperatures/°C	
Charge	-15 to 50
Discharge	-20 to 60
10) Percentage Charge Retention at 20°C	
1 month	97
3 months	91
6 months	85
11) Standard Terminal Type	Lead post with brass insert C
12) Torque Nm	4.76
13) Case Material	ABS
Dimensions / mm	
Length +/-1	350
Width +/-1	166
Height +/-2	174

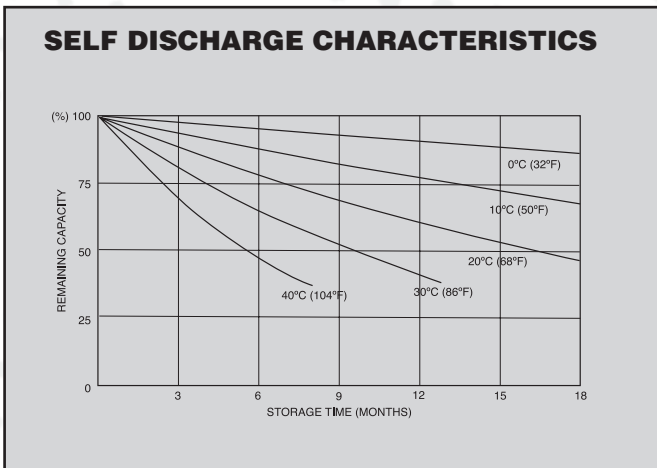
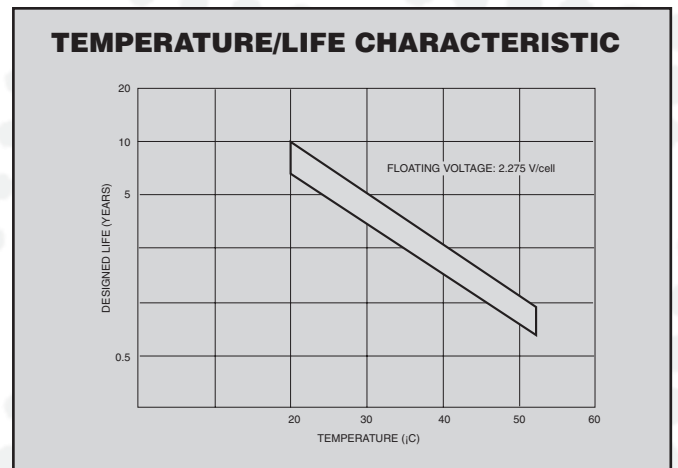
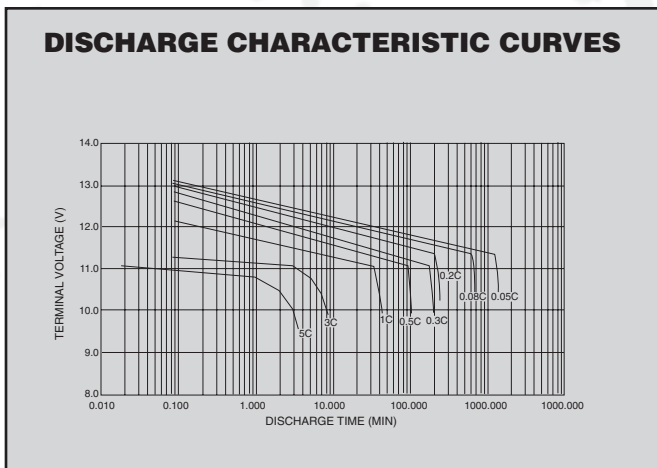
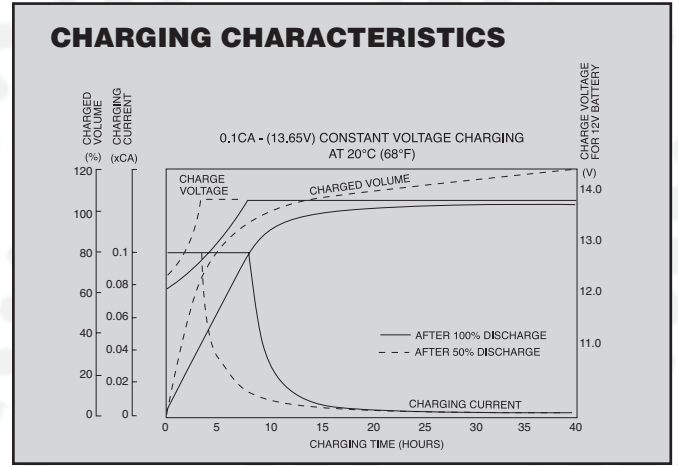
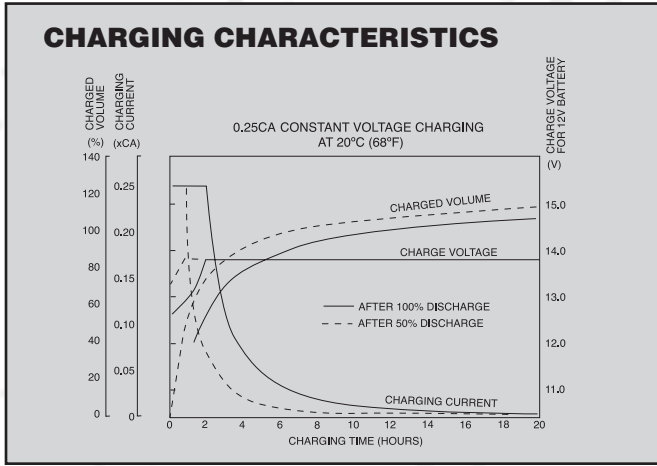

Charging Methods (At 20°C)

Standby use: Float charging voltage 2.275vpc

CAUTION

- Avoid short circuit.
- Do not charge in a sealed container.
- Service life and operational characteristics will be affected by temperature.
- AC Ripple reduces service life.

WARNING!

SWL (Standard) and (FR) battery types SWL1850; SWL1850-6; SWL2500, must never be installed permanently suspended by their handles; they are not designed for this purpose.



Yuasa Battery Sales (UK) Ltd

Unit 22 Rassau Industrial Estate
Ebbw Vale, Gwent, NP23 5SD
Tel: 08708 500312 Fax: 08708 500317
E-mail: enquiries@yuasa-sales.co.uk

Registered number 1548820

Cat. No. SWL1800 February 07

E&O.E.

Distributed by