

ULTRA MAX LITHIUM STANDARD (CR2025) Coin Cell

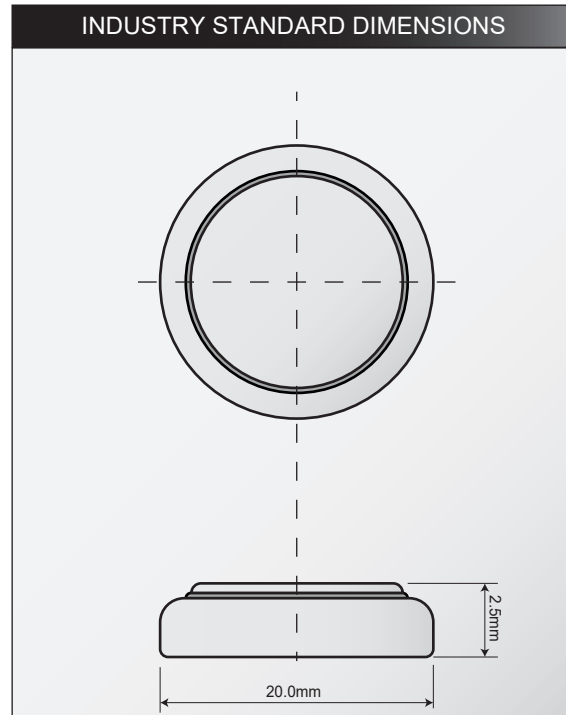

SPECIFICATION	
DESIGNATION	CR2025
NOMINAL VOLTAGE	3.0V
TYPICAL CAPACITY	150mAh
TYPICAL WEIGHT	2.3g
TYPICAL VOLUME	1.0cm ³
INSTANT SHORT-CIRCUIT CURRENT	≥250mA
CHEMICAL SYSTEM	Lithium Manganese Dioxide
SELF-DISCHARGE RATE	≤1% per year
OPERATING TEMPERATURE RANGE	-20°C~60°C

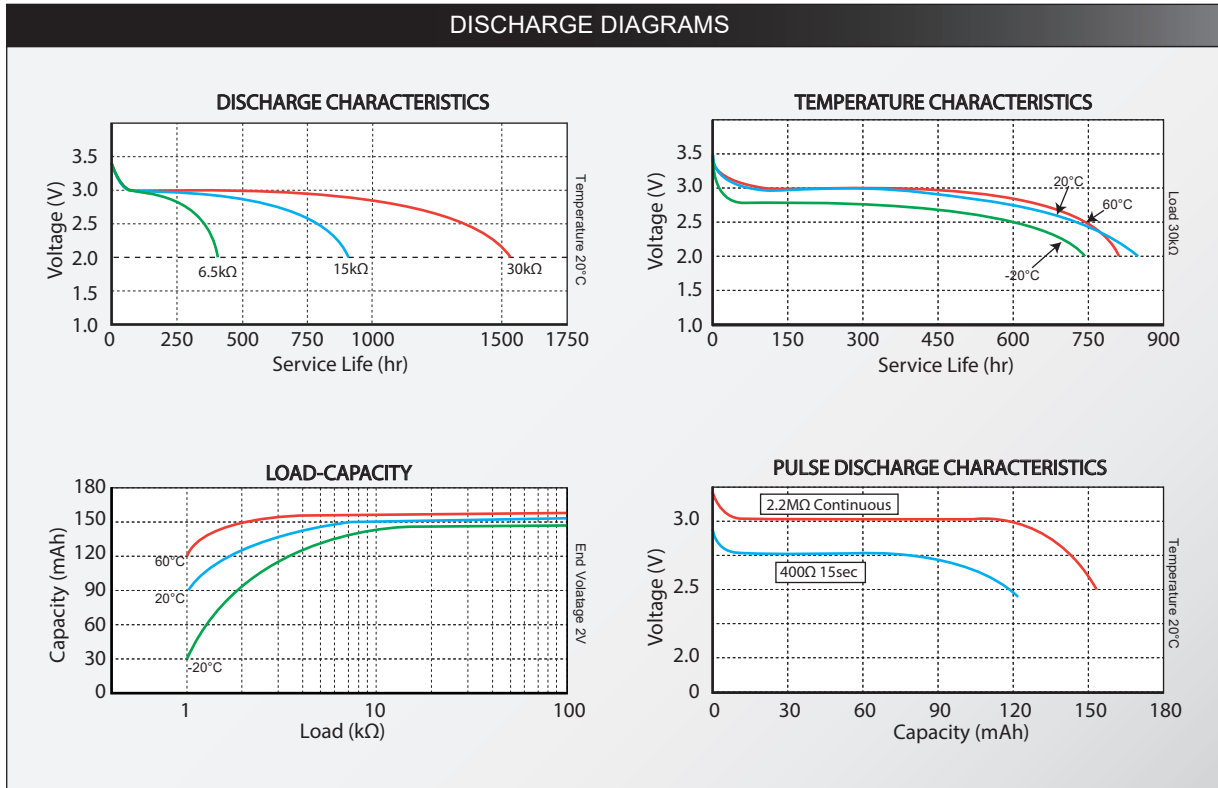

Important Notice

Delivered capacity is dependent on the applied load, operating temperature and cut-off voltage. Please refer to the charts and discharge data shown.

This specification contains typical information specific to products manufactured at the time of publication. The data is subject to change and should be used for reference only. Contact UltraMax for the latest information.